

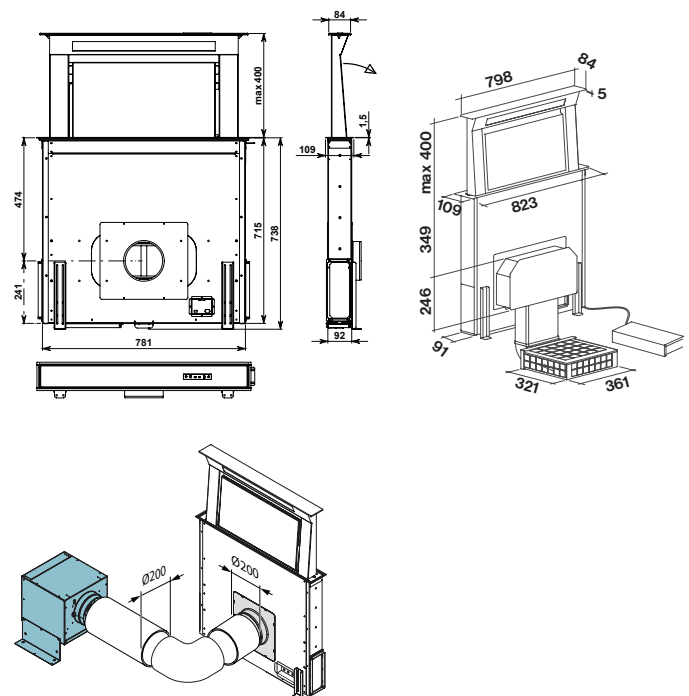

Product Features

Motor Type	Off Board
Dimensions	798(W) x 400(H) x 84(D)mm Suits 50cm-90cm Cooking Surfaces
Benchtop Cut-Out	810 x 98mm
Filtration Type	Perimeter Suction
Lighting	LED Strip
Controls	Touch Controls
Speed Settings	3 Speed + Boost
Timer Function	15 Min Auto Shut-Off
Accessories	EW1000 - 6 m of 150 mm ducting, 1 x rectangle to round adaptor. UC600 – Carbon Zero filter and baseboard vent. IN1300 – 6 m of 200 mm ducting, 1 x 200 mm circular elbow, 1 x 200 mm flange and 1 x 200 mm round wall vent.
Remote Control	Optional
Grease Filter Alarm	Yes
Dishwasher Safe Filters	Yes

Dimensioned Drawings



Model Code	Motor Output	Finish
F8DD90B1-UC600	600 m ³ /hr	Black Glass
F8DD90B1-EW1000	1000 m ³ /hr	Black Glass
F8DD90B1-IN1300	1300 m ³ /hr	Black Glass

DOWN DRAFT

Version

Remote under-roof motor 950
m³/h

Collection

Design+

EAN code

8034122348094

MOTOR TECHNICAL SHEET

Motor speed	1	2	3	4
Noise level dB(A) _{re1pW-I.E.C.60704-2-13}	51	59	64	68
Capacity (m ³ /h) I.E.C.61591	330	480	610	730
Maximum pressure (Pa)	460	520	560	580
Motor Power (W)	187	210	225	240
Air outlet	150	150	150	150

CAPACITY / PRESSURE

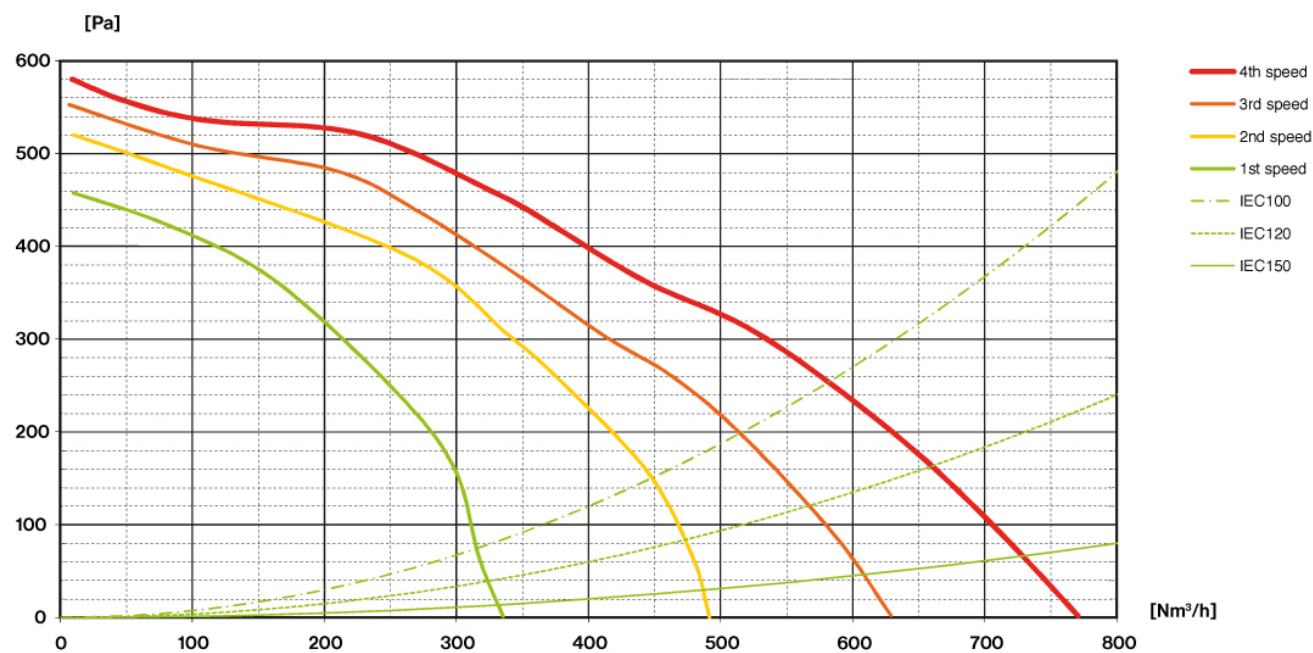

DOWN DRAFT

Version

Remote under-roof motor 950
m³/h

Collection

Design+

EAN code

8034122348094

ENERGY LABEL

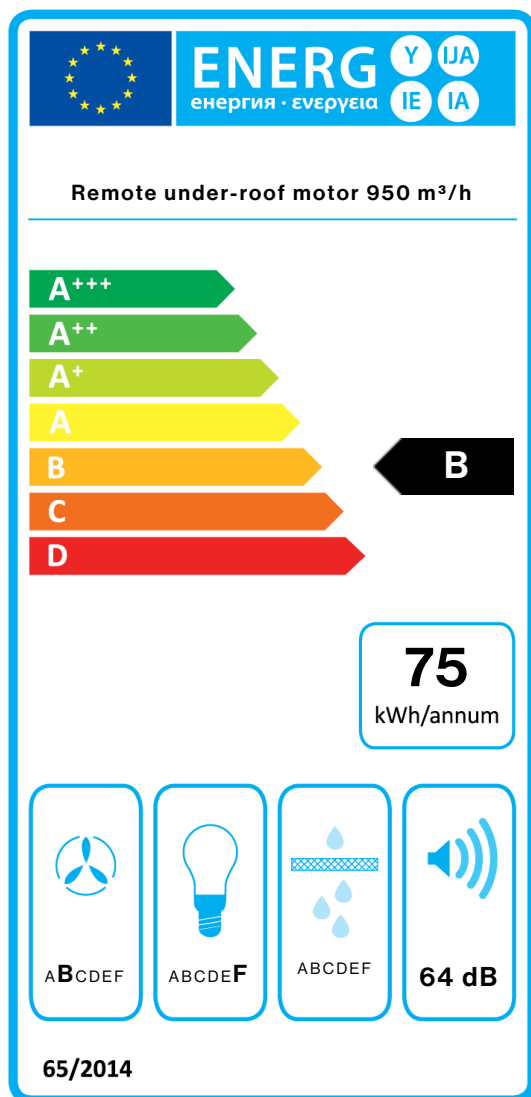

PF		
S	Falmec Spa	
M	Remote under-roof motor 950 m ³ /h	
AEC	75,4	kWh/a
EEC	B	
FDE	24,6	
FDEC	B	
LE	6,5	
LEC	F	
GFE	36,0	
GFEC	G	
Qmin	330,0	m ³ /h
Qmax	610,0	m ³ /h
Qboost	730,0	m ³ /h
SPEmin	51	dBa
SPEmax	64	dBa
SPEboost	68	dBa
PO	-	W
PS	0,95	W
PI		
F	1.1	
EEl	65,2	
Qbep	369,0	m ³ /h
Pbep	422	Pa
Qboost	730,0	m ³ /h
Wbep	176,0	W
WL	6,50	W
Emiddle	42	lex
Lwa-SPEmax	64	dBa

PF_Product fiche according to 65/2014 S_Supplier name / M_Model identification / AEC_Annual Energy Consumption (AEC hood) / EEC_Energy Efficiency class / FDE_Fluid Dynamic Efficiency (FDE hood) / FDEC_Fluid Dynamic Efficiency class / LE_Lighting Efficiency (LE hood) / LEC_Lighting Efficiency class / GFE_Grease Filtering Efficiency / GFEC_Grease Filtering Efficiency class / Qmin_Air flow (in m³/h) at min speed in normal use / Qmax_Air flow (in m³/h) at max speed in normal use / Qboost_Air flow (in m³/h) at intensive or boost setting (max air-flow) / SPEmin_Airborne acoustical A-weighted sound power emissions at min speed in normal use / SPEmax_Airborne acoustical A-weighted sound power emissions at max speed in normal use / SPEboost_Airborne acoustical A-weighted sound power emissions (in dB) at intensive or boost setting / PO_Power consumption in off mode (Po) / Ps_Power consumption in stand by mode (Ps). **PI_Additional information according to 66/2014** F_Time increase factor / EEl_Energy Efficiency Index / Qbep_Measured air flow rate at best efficiency point / Pbep_Measured air pressure at best efficiency point / Qboost_Maximum air flow / Wbep_Measured electric power input at best efficiency point / WL_Nominal power of the lighting system / Emiddle_Average illumination of the lighting system on the cooking surface / Lwa=SPEmax_Sound pressure level at the highest speed.

CARATTERISTICHE TECNICHE MOTORI / MOTORS SPECS SHEET

Versione / Version

Aspiratore esterno 1000 m³/h
Outdoor extractor fan 1000 m³/h

DATI MOTORE / MOTOR DATA

Velocità motore / Speed motor	1	2	3	4
Rumorosità / Noise dB(A)re1pW-I.E.C.60704-2-13	67	70	73	75
Portata / Capacity (m ³ /h) I.E.C.61591	750	850	920	950
Pressione / Pressure (Pa)	380	440	460	480
Potenza motore Power motor (W)	140	145	150	160
Air outlet Ø	150	150	150	150

PORTATA / PRESSIONE CAPACITY / PRESSURE

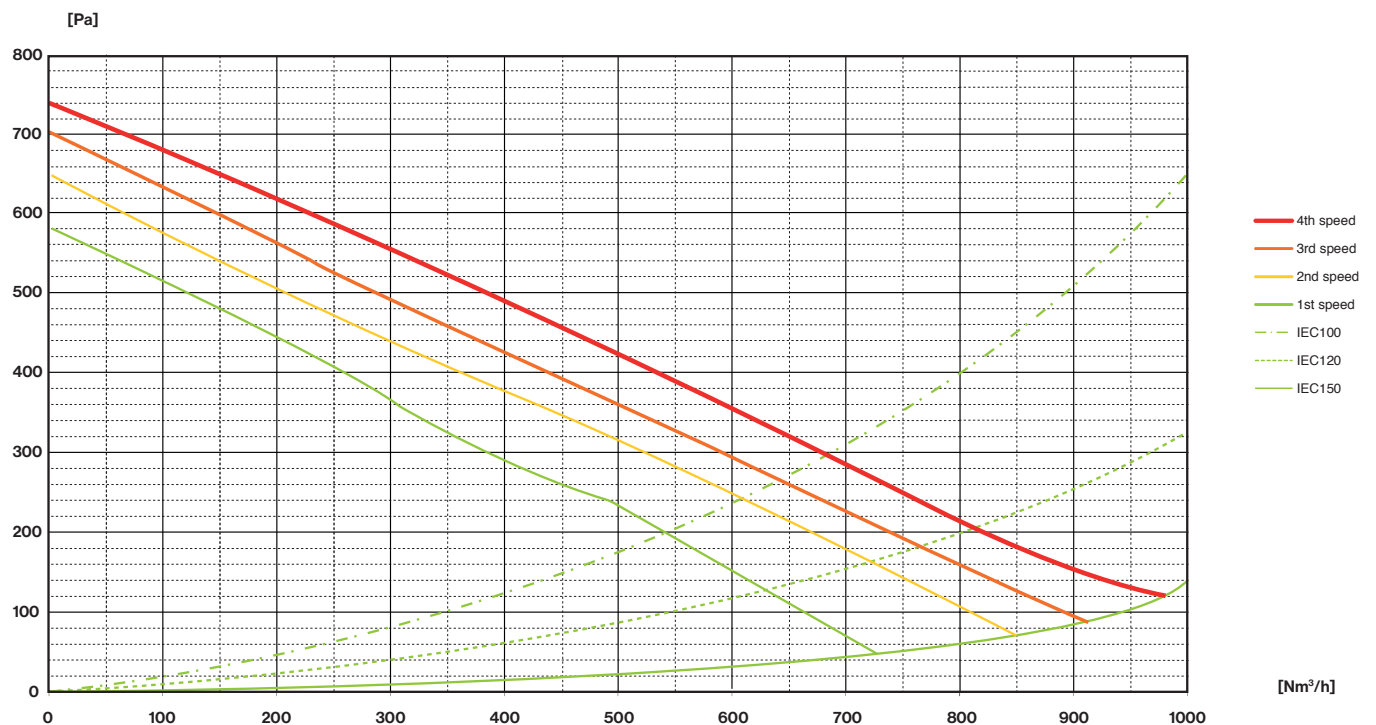

CARATTERISTICHE TECNICHE MOTORI / MOTORS SPECTS SHEET

Versione / Version

Motore remoto 1300 m³/h
Remote motor 1300 m³/h

DATI MOTORE / MOTOR DATA

Velocità motore / Speed motor	1	2	3	4
Rumorosità / Noise dB(A)re1pW-I.E.C.60704-2-13	50	58	63	68
Portata / Capacity (m ³ /h) I.E.C.61591	450	650	800	1230
Pressione / Pressure (Pa)	420	500	520	560
Potenza massima motore Max power motor (W)	-	-	-	450
Air outlet Ø	200	200	200	200

PORTATA / PRESSIONE CAPACITY / PRESSURE

