

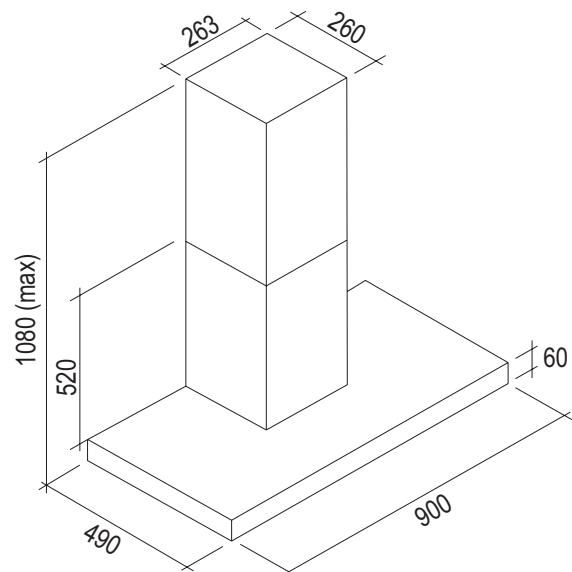

Product Features

Motor Type	Off Board Motor
Dimensions	900 x 490 x 1080mm Suits 75cm-100cm cooking surfaces
Filtration Type	Baffle Filters x 3
Lighting	Adaptive Dynamic LED Strip
Finish	AISI304 Scotch Brite Stainless
Controls	Touch Control (Remote Control Optional)
Speed Settings	3 Speed + Boost
Timer Function	15 Min Auto Shut-Off
Ducting	200mm Circular Outlet + 5m of flexible ducting supplied
Other	N/A

Dimensioned Drawings



Model Code	Motor Output	Installation Option
FP5TV90S2-IR765	765 m ³ /hr	In Roof Motor
FP5TV90S2-ER765	765 m ³ /hr	External Roof Motor
FP5TV90S2-EW765	765 m ³ /hr	External Wall Motor
FP5TV90S2-IR1140	1140 m ³ /hr	In Roof Motor
FP5TV90S2-ER1140	1140 m ³ /hr	External Roof Motor
FP5TV90S2-EW1140	1140 m ³ /hr	External Wall Motor