

---

# ICNh 5103

---

Integrated fridge-freezer with  
EasyFresh and NoFrost

# LIEBHERR

Fully Integrated

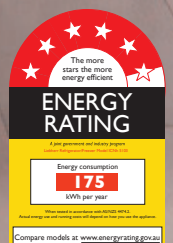

Fully Integrated

# ICNh 5103

Pure

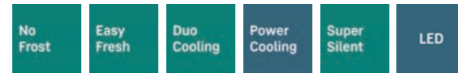

Total Usable Volume Litres	253
Energy Consumption (kWh/yr) I Star rating	175 / 5.5
Climate Rating	SN-T (+10°C to +43°C)
Noise Output	35 dB(A)
Display	Touch
Defrosting	Automatic
Frequency / Voltage	50-60 Hz / 220-240 V~
Connection Rating	1.4 A 183 W

<b>Refrigerator</b>	
Forced air system	PowerCooling
FreshAir Activated Charcoal Filter	Yes
Interior Light	LED
Drawers	1 EasyFresh
GlassLine Door interior	Yes
Rear Wall	White Polystyrol
Inside Door	White Polystyrol

<b>Freezer</b>	
Freezing Capacity in 24 hours	6 kg
Number of Drawers	3

<b>Type of Appliance</b>	
Type	Integrated Fridge / Freezer Combination
Door Assembly	Integrated Door on Door

<b>Intallation Dimensions</b>	
Height	177.2-178.8 cm
Width	56-57 cm
Depth	min. 55 cm

<b>Other</b>	
Smart DeviceBox	Optional
Door Hinges	right, reversible
EAN	4016803073352

Fully Integrated

## Features



### NoFrost

When you open your freezer, you want to see frozen food – and certainly not ice and frost. NoFrost protects the freezer compartment from unwanted icing, which consumes a lot of energy and can be expensive. NoFrost means no more tedious and time-consuming defrosting of the freezer compartment, more time for other things – and saving money.



### EasyFresh

The guarantee of market freshness in the home is our EasyFresh-Safe. Whether it's unpackaged vegetables or fruit, this ensures optimal storage for everything. Thanks to the air-tight closure, the food causes the humidity in the safe to rise. This keeps the food fresh for a long time.



### DuoCooling

DuoCooling uses two completely separate refrigeration circuits to ensure no air is exchanged between the fridge and freezer compartments. The food neither dries out nor is odour transferred. This means throwing less away, shopping less often, but saving more and greater enjoyment.



### Touch display

Fingertip control: the touch display enables easy and intuitive operation of your Liebherr. All functions are clearly arranged on the display. By gently tapping a finger, for example, you can easily select the functions or check the current temperature of your refrigerator.



### Space for baking tray

Do you want to keep that home-baked fruit pie fresh? Or maybe a prepared pizza to be baked later on? If so, simply slide your baking tray into your Liebherr – it has plenty of space for storing a baking tray. Really convenient – you can slide the baking tray in and out when the door is opened at 90°.



### PowerCooling system

Do you want to be sure that the cold is distributed as evenly as possible in your refrigerator? If so, the PowerCooling system is what you need. The fan – as powerful as it is quiet – distributes the cold air efficiently throughout the entire refrigeration compartment.

# Diagrams

## Installation Diagram

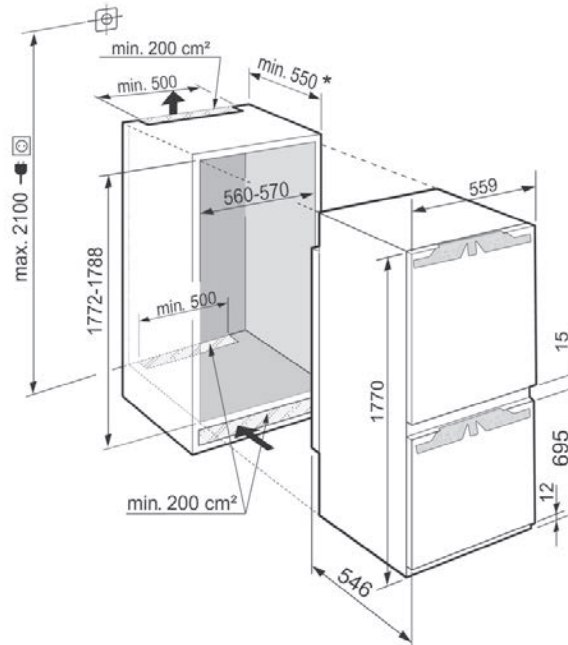

\* Recommended: 560 mm

Products and their details are staged for advertising purposes. Whilst every effort is made to ensure all specifications and information in this flyer are accurate, Liebherr reserves the right to make changes without notification. Where actual appliance measurements, specifications, and ratings are crucial, we recommend that the actual appliance installation instructions that accompany each appliance be checked. Liebherr will not be liable for any loss. (09.02.2022)