

BEVERAGE CENTRE

UKes 1752



LIEBHERR

Quality, Design and Innovation

LIEBHERR INDOOR BEVERAGE CENTRE UKes 1752

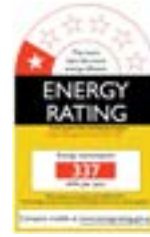
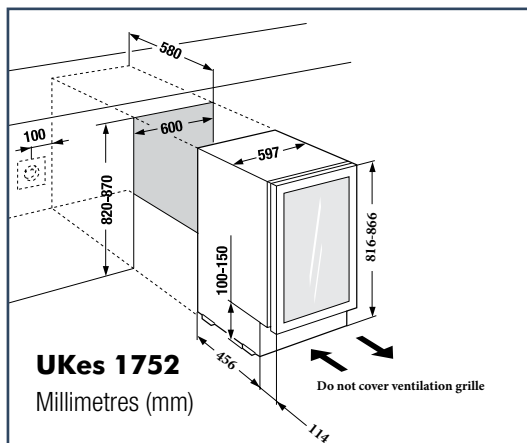

Built-in

3 Year Warranty

Model	UKes 1752
Type I Category	BI - UB
Finish	Stainless Steel
Energy consumption (kWh/yr) 24hr	337 0.923
Total gross net capacity (L)	131 108
Safety glass door	•
MagicEye control system Display	• LED
Digital temperature display	Internal
Tinted glazed door	Double
Temperature zones	1
Temperature range (°C) Min Max °C	2 20
Suitable for ambient temperature Min Max °C	16 43
Interior light	LED
Base shelves	1
Glass shelves	2
One of the glass shelves is sectionable	•
Wire shelves	1
Recirculated air cooling	•
Child proof lock (control panel)	•
Ergonomic SlimLine handles	•
Reversible door hinges	•
Key lock	•
Compressors	1
Door open warning signal	•
Temperature alarm	•
Adjustable height by 50mm	•

Technical Information

Default hinge	Right
Gross weight (kg) Net weight (kg)	52 46
Height (mm)	820 - 870
Width (mm)	600
Depth (mm)	580
Voltage (V) Rated Current (A)	220-240 0.8
Made in	Austria

Suitable for food & beverage storage

KEY: UB = Underbench, BI = Built-In.
Door hinging either right or left hand must be nominated for this model.

Whilst every effort is made to ensure all specifications and information in this flyer are correct at time of printing, Andi-Co Australia Pty. Ltd. reserve the right to make changes without notification. Where actual appliance measurements, specifications and ratings are crucial, we recommend that the actual appliance installation instructions that accompany each appliance be checked. Andi-Co Australia will not be liable for any loss.