

Designed to Enhance
EST. 1981

omega

Installation + User Manual
OCBFS102SB

102 Can Beverage Centre Single Zone

Contents

03 [Welcome](#)

04 [Safety Information](#)

09 [Your Beverage Centre](#)

11 [Installing Your Beverage Centre](#)

14 [Operating Instructions](#)

16 [Cleaning & Maintenance](#)

17 [Troubleshooting](#)

18 [Technical Specifications](#)

19 [Purchase Details](#)

22 [Warranty Information](#)

Welcome

Residentia Group

Office 165 Barkly Avenue Burnley
Victoria Australia 3121

ACN 70 600 546 656

Online residentia.group
omegaappliances.com.au

Post PO BOX 5177 Burnley
Victoria Australia 3121

Phone 1300 11 4357

Email support@residentia.group

Congratulations on purchasing your new Beverage Centre!

Omega appliances are proudly owned, distributed, designed and engineered in Australia by Residentia Group Pty Ltd.

Please refer to the warranty chapter at the rear of this manual for information regarding your product's parts and labour warranty, or visit us online at:

→ www.residentiagroup.com.au

Here at Residentia Group, we are customer obsessed and our Support Team are there to ensure you get the most out of your appliance. Should you want to learn more about your unit, and importantly, taking care of the appliance, our Support Team are here to help. You can use our online Support Centre at any time by visiting:

→ www.support.residentiagroup.com.au

Or you can contact us by dialling: 1300 11 HELP (4357)

It is important that you read through the following user manual thoroughly, in order to familiarise yourself with the installation and operation requirements of your appliance, and to ensure optimum performance.

Again, thank you for choosing an Omega appliance and we look forward to being of service to you.

Kind Regards,

The Residentia Team

Customer Care

At Residentia Group, we strongly encourage the use of authentic spare parts to guarantee the best results. When contacting our spare parts team through 1300 11 HELP, or by emailing parts@residentiagroup.com.au, please ensure that you have the model and serial numbers on hand, which are found on your appliances' rating plate.

Safety Information

Important Safety Instructions

Read Carefully and Keep for Future Reference

Read this manual thoroughly before first use, even if you are familiar with this type of product. The safety precautions enclosed herein reduce the risk of fire, electric shock and injury when correctly adhered to. Make sure you understand all instructions and warnings.

Keep the manual in a safe place for future reference, along with the completed warranty card and purchase receipt. If you sell or transfer ownership of this product, pass on these instructions to the new owner.

Always follow basic safety precautions and accident prevention measures when using an electrical appliance. The following statements you will see in this booklet have these meanings:

WARNING: Indicating information concerning your personal safety.

CAUTION: Indicating information on how to avoid damaging the appliance or cabinetry.

IMPORTANT: Indicating tips and information about use of the appliance.

Usage Conditions and Restrictions

- Domestic use only: This appliance is intended for indoor household use only. It is not intended for commercial, industrial or outdoor use. It is not intended for use in a recreational vehicle.
- Purpose: Do not use this appliance for anything other than its intended purpose. Other uses are not recommended and may cause fire, electric shock or personal injury.
- Attachments: The use of attachments is not recommended by the appliance manufacturer and distributor as they may be hazardous.
- Improper use: Damage due to improper use, or repairs made by unqualified personnel will void your warranty. We assume no liability for any eventual damages caused by misuse of the product or non-compliance with these instructions.

Before Using Your Appliance

This manual explains the proper use of your Omega Beverage Centre. Please read this manual carefully before using the product.

This manual should be kept in a safe place for handy reference.

This Beverage Centre is a domestic appliance which has been manufactured and tested to comply with Australian and New Zealand Standards.

This Beverage Centre must only be installed in accordance with the instructions provided. Incorrect installation may cause harm to persons, damage property and void the product's warranty.

Read the following carefully to avoid damage or injury.

IMPORTANT: Check for any damage or marks. If you find the appliance is damaged or marked, you must report it within 7 days if you wish to claim for damage/ marks under the manufacturer's warranty. This does not affect your statutory rights.

Safety Instructions

- Before the installation and use of the appliance, carefully read the supplied instructions.
- The manufacturer is not responsible if an incorrect installation and use causes injuries and damages.
- Always keep the instructions with your appliance for future reference.
- If you will not use the appliance for a long time, it is advised to turn the plug off.

WARNING: To prevent any damages to your and others' life or property, you have to follow these safety instructions.

WARNING: When positioning the appliance, ensure the supply cord is not trapped or damaged.

WARNING: Do not locate multiple portable socket-outlets or portable power supplies at the rear of the appliance.

Safety Information

Children & Vulnerable People Safety

WARNING: Risk of suffocation, injury or permanent disability.

This appliance is not intended for use by persons (including children) with reduced physical, sensory or mental capabilities, or lack of experience and knowledge, unless they have been given supervision or instruction concerning use of the appliance by a person responsible for their safety.

- Children should be supervised to ensure that they do not play with the appliance.
- Keep all packaging away from children.
- Cleaning and user maintenance shall not be made by children without supervision.

Unpacking

- During transportation, protective packaging was used to protect the appliance against any damage. After unpacking, please dispose of all elements of packaging in a way that will not cause damage to the environment.
- All materials used for packaging the appliance are environmentally friendly; they are 100% recyclable and are marked with the appropriate symbol.
- Remove all the packaging.

CAUTION: During unpacking, the packaging materials (polythene bags, polystyrene pieces, etc.) should be kept out of reach of children.

- Always move the appliance cautiously. Do not use the machine door to lift the appliance.

WARNING: Do not damage the refrigerant circuit at the rear.

WARNING: If you suspect refrigerant leakage, avoid touching the unit or power outlet. Ventilate the room and, if possible, turn off the unit using the circuit breaker. Contact the manufacturer immediately. Refrigerant can cause serious injury upon contact with skin or eyes; seek medical treatment promptly if exposed.

- Do not install or use a damaged appliance.
- Before installation or cleaning, disconnect the appliance from the power source and reset temperature controls. Reconnect and reset after completing tasks.
- Please contact 1300 11 HELP (4357) to arrange an authorised technician if you need assistance with installing the appliance.

Electrical Connection

CAUTION: Risk of fire and electrical shock!

- Ensure the appliance's plug is easily accessible.
- Ensure proper grounding of the appliance before operation. The appliance must be earthed.

WARNING: If you are unsure about grounding instructions, consult a qualified electrician or service person. Wait at least 5 minutes before reconnecting the power cord to prevent freezer failure.

- Make sure that the electrical information on the rating plate agrees with the power supply. If not, contact an electrician.
- Always use a correctly installed shockproof socket.
- Do not use any multi-plug adapters or extension cables.

WARNING: Incorrect grounding may lead to breakdowns or electric shocks. Use a dedicated outlet; using multiple devices on one outlet may cause fire hazards. Avoid positioning the power plug upwards or in a squeezed space at the back of the fridge to prevent water damage or fire risk.

- Ensure the supply cord is not trapped or damaged during positioning.
- Connect the mains plug to the mains socket only at the end of the installation. Make sure that there is access to the mains plug after the installation. Do not connect the appliance plug with a power connection board.
- Do not pull the mains cable to disconnect the appliance. Always pull the mains plug.
- Do not touch the mains cable or the mains plug with wet hands.

WARNING: If the supply cord is damaged, it must be replaced by the manufacturer or its service agent or similarly qualified person in order to avoid a hazard.

WARNING: All electrical work must be done in accordance with local and national electrical codes as applicable and should be undertaken by licenced and qualified persons only. Failure to follow these instructions can result in death, fire or electrical shock.

This product operates on 220-240V/50Hz only. It cannot be used with frequencies other than 50Hz.

To ensure safety, the socket and its cable must be capable of withstanding a current of above 13A.

Safety Information

Appliance Placement

- Use this appliance in a domestic household only.
- Avoid installing it in wet or high humidity environments to prevent deterioration and electrical hazards.
- Install the appliance in a dry, well-ventilated room close to a wall outlet for easy access to power supply in case of accidents.
- Avoid exposing the unit to extreme heat or open flame, and ensure adequate airflow around the unit to prevent electric shock or injury.
- Do not cover or obstruct any ventilation areas of the unit to avoid electric shock or injury.

Care & Cleaning

CAUTION: Risk of injury or damage to the Beverage Centre.

- Before installation or cleaning, disconnect the appliance from the power source and reset temperature controls. Reconnect and reset after completing tasks.
- Unplug the power cord when cleaning or handling the interior lamp to prevent electric shock or injury. Use a dry, clean cloth to remove water or dust from the power plug; do not touch it with wet hands. Ensure the power cord is not bent or pressed by heavy objects to avoid damage.
- Do not use a steam cleaner on the appliance.
- Avoid spraying water inside or outside the fridge or cleaning it with benzene or thinner.
- Use caution with cleaning agents; acidic cleaners, abrasive brushes, sharp tools, or those containing benzene should not be used.
- Clean the appliance with a moist soft cloth. Only use neutral detergents. Do not use abrasive products, abrasive cleaning pads, solvents or metal objects.

Appliance Use

WARNING: Risk of fire, explosion, electric shock or damage to the appliance.

WARNING: Keep ventilation openings, within the appliance enclosure or surrounding the appliance, clear of obstruction.

WARNING: This appliance is not suitable for food storage and must not be used to store food inside.

- Do not change the specification of this appliance.
- Do not store explosive substances such as aerosol cans with a flammable propellant in this appliance.
- Please do not close the appliance door with excessive force
- Avoid placing heavy or dangerous objects inside the appliance, as they may cause injury, fire, or electric shock.
- Do not use a dryer or light a candle inside the unit, as it may cause explosion or fire.
- Avoid clinging to the door, especially for children, to prevent the appliance from falling and causing serious injuries or death.
- This appliance contains the coolant Isobutane (R600a), a natural gas which is environmentally friendly. Although it is flammable, it does not damage the ozone layer and does not increase the greenhouse effect. The use of this coolant has, however, led to a slight increase in the noise level of the appliance. In addition to the noise of the compressor, you might be able to hear the coolant flowing around the system. This is unavoidable, but does not have any adverse effect on the performance of the appliance.



The refrigerant (R600a) is flammable.

Symbol ISO 7010 W021

WARNING: Risk of fire/flamable materials!

Safety Information

To avoid contamination of drinks, pay attention to the following:

- Opening the door for long periods of time can cause a significant increase in the temperature in the compartments of the appliance.
- Only store beverages in sealed containers.
- Do not overload the cabinet.
- Only open the door when necessary.
- This is a self-defrosting appliance. The compressor will not run during the twenty minutes defrost cycle.
- Do not pull the shelves beyond the anti-stop position when fully loaded.
- This appliance is intended to be used exclusively for the storage of beverages.
- In the event of a power failure, leave the door closed as much as possible to maintain the internal working temperature. Should the power failure continue for a prolonged period, you should take steps to protect the contents of the Beverage Centre against a rise in temperature. The Beverage Centre will remember the selected temperature setting and revert to these setting once the power is restored.

Disposal of the Appliance

- Disconnect the appliance from the mains supply, cut off the mains cable and discard it.
- Remove the doors and secure shelves before discarding old refrigerators or freezers to prevent injury or children and pet entrapment.
- When discarding the unit, keep it away from extreme heat sources due to flammable refrigerant and foaming agent.
- Adhere to local laws and regulations when discarding the appliance.
- Old appliances should not simply be disposed of with normal household waste and should be delivered to a collection and recycling centre for electric and electronic equipment. A symbol shown on the product, the instruction manual or the packaging shows that it is suitable for recycling.



- Dispose of refrigerant and insulation blowing gas at authorised waste disposal centers. Avoid exposing them to extreme heat or open flames.
- The packaging is designed to protect the appliance from damage during transportation. The packaging materials are environmentally friendly and should be recycled. Recycling the packaging can reduce the use of raw materials in the manufacturing process and the amount of waste in landfill sites.
- Packaging materials of the product are manufactured from recyclable materials in accordance with our National Environment Regulations. Do not dispose of the packaging materials together with the domestic or other wastes. Take them to the packaging material collection points designated by the local authorities.
- Materials used inside the appliance are recyclable and are labelled with information concerning this. By recycling materials or other parts from used devices you are making a significant contribution to the protection of our environment.
- Information on appropriate disposal centres for used devices can be provided by your local authority.

Safety Information

Unpacking

- During transportation, protective packaging was used to protect the appliance against any damage. After unpacking, please dispose of all elements of packaging in a way that will not cause damage to the environment.
- Remove the packaging box and take off the top foam.
- Remove the protective foam from the sides and inside the Beverage Centre.
- Lift the Beverage Centre with assistance to remove the foam pad underneath.
- Open the Beverage Centre door and take out the installation accessories and other items stored inside.
- All materials used for packaging the appliance are environmentally friendly; they are 100% recyclable and are marked with the appropriate symbol.
- Before switching on your appliance for the first time, ensure it is positioned in its desired final location and is in its upright position for at least 24 hours before plugging in and switching on the power, otherwise you may damage the compressor.
- You may experience an odour from the appliance when it is operated for the first time. This is normal and will fade when your appliance starts to cool.
- It is recommended that you remove all the internal and external packaging and clean the interior of the appliance prior to first use. We recommend you wipe all parts with warm water, then rinse and dry. Place all parts back into the appliance after cleaning.

CAUTION: During unpacking, the packaging materials (polythene bags, polystyrene pieces, etc.) should be kept out of reach of children.

Declaration of Compliance

When you have unpacked the appliance, make sure that it has not been damaged in any way. If you have any doubts at all, do not use it: contact a professionally qualified person. Keep packing materials such as plastic bags, polystyrene, or nails out of the reach of children because these are dangerous to children.

Climate Classes

Each appliance has a climate class (shown on the rating label) where it indicates the temperature range of the appliance operation in place. The appliance may not work properly if it is left for a long period at a temperature outside the specified range.

- **Extended temperature (SN):**
This refrigerating appliance is intended to be used at ambient temperatures ranging from 10°C to 32°C.
- **Temperate (N):**
This refrigerating appliance is intended to be used at ambient temperatures ranging from 16°C to 32°C.
- **Subtropical (ST):**
This refrigerating appliance is intended to be used at ambient temperatures ranging from 16°C to 38°C.
- **Tropical (T):**
This refrigerating appliance is intended to be used at ambient temperatures ranging

Refer to the Operating Instructions section of this user manual on how to set temperature of your unit.

Your Beverage Centre

Components, Parts and Accessories

Model: OCBFS102SB

A. Cabinet

B. Digital Touch Controls

C. Wire Shelves (x4)

D. Stability Feet (x4)

E. Double glazed, UV Glass Door

F. Reversible Door Hinge

G. LED Internal Lighting

H. Door Lock

* User Manual (x1)

* Quick Start Guide (x1)

* Not pictured, also available online: www.omegaappliances.com.au



Note: The diagrams and images in this user manual are for explanatory purposes only. Your appliance may appear differently.

Your Beverage Centre

Product Dimensions

The dimensional diagrams for this appliance provide essential information about its size and layout. These diagrams detail the fridge's measurements enabling you to plan its placement effectively.

Note: The diagrams and images in this user manual are for explanatory purposes only. Your appliance may appear differently.

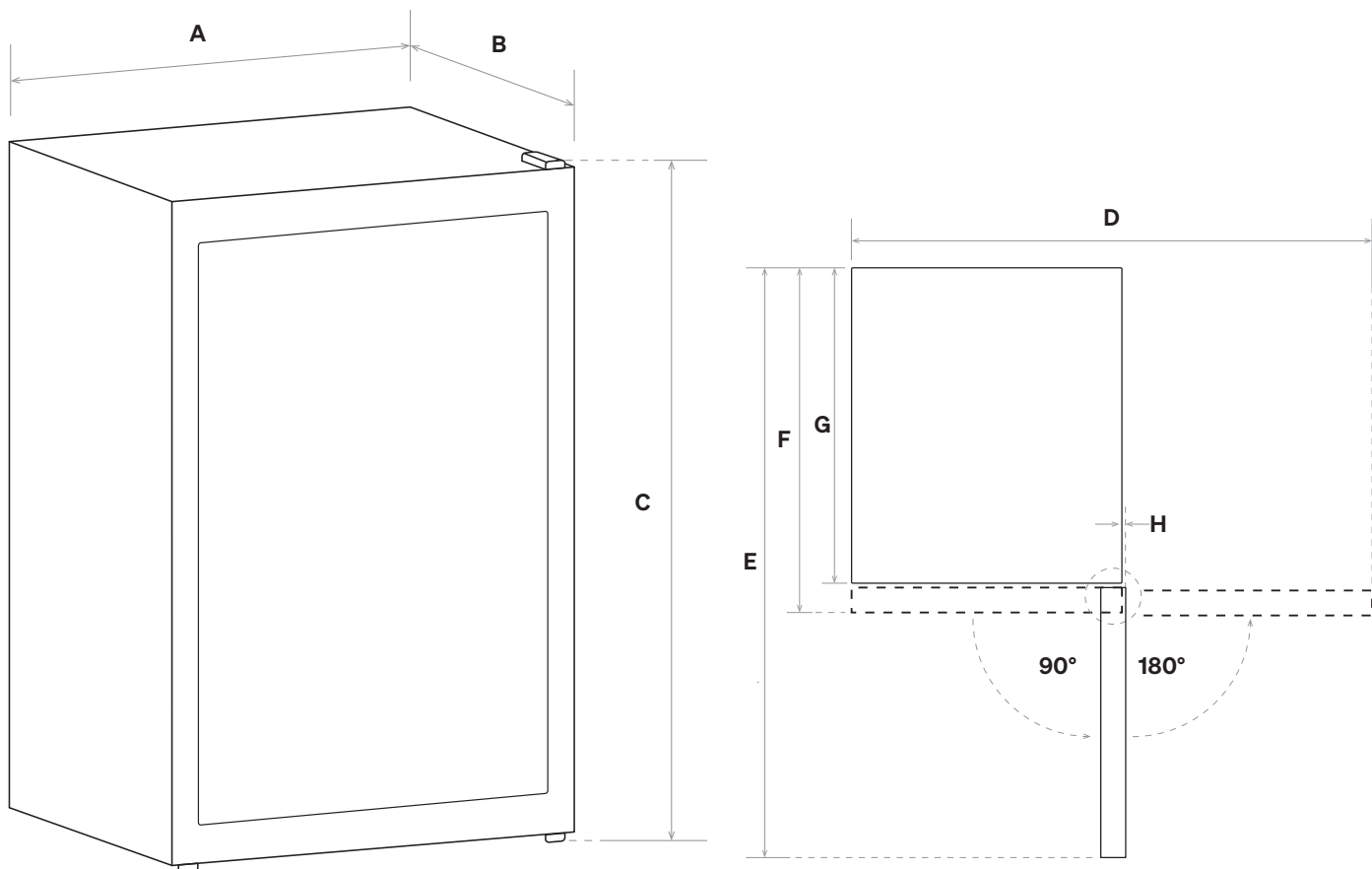

Dimensions (mm)

A	470	C	840	E	915.8	G	426.2
B	475	D	917	F	474.3	H	5.5

Installing Your Beverage Centre

Transportation

- Avoid transporting the Beverage Centre horizontally or laying it down. Keep it upright during transportation to prevent damage.
- When moving the Beverage Centre, refrain from holding onto the door. Always lift the appliance from the bottom to ensure safe handling.
- Never attempt to move the unit alone. It is essential to have at least two people to safely lift or move the Beverage Centre. This precaution helps prevent injury and ensures the unit remains intact during transportation.

Unpacking

- During transportation, protective packaging was used to protect the appliance against any damage. After unpacking, please dispose of all elements of packaging in a way that will not cause damage to the environment.
- Remove the packaging box and remove the protective foam.

CAUTION: During unpacking, the packaging materials (polythene bags, polystyrene pieces, etc.) should be kept out of reach of children.

Positioning Your Beverage Centre

- The Beverage Centre must be positioned on a firm, solid, level surface to ensure the appliance operates efficiently and doesn't wobble.
- Keep the Beverage Centre away from damp areas where water is present. Promptly remove any water or dirt from the surfaces using a soft cloth to prevent rust and maintain optimal efficiency.
- Keep the Beverage Centre away from heat sources like stoves, ovens, and direct sunlight. Heat can affect the performance and energy consumption.
- Do not place your appliance in direct sunlight.
- Your appliance should be at least 50 cm away from stoves, gas ovens and heaters, and should be at least 5 cm away from electrical ovens.
- Your Beverage Centre should never be used outdoors or left out in the rain. Your Beverage Centre may not function correctly if the ambient temperature exceeds 43° C.
- If your Beverage Centre is placed next to a deep freezer, there should be at least 2 cm between each other to prevent humidity on the outer surface.

Installation

This Beverage Centre is designed for freestanding use only and should not be Built-in (Integrated) into any cabinetry. For freestanding installation, ensure the unit meets the specifications below. The diagram below gives the dimensions of the minimum required clearances.

- Ensure the mains connection is easily accessible.
- The power socket should be located in an adjacent cabinet for easy access.
- Two person installation: Use two or more able-bodied people to move and install the Beverage Centre. Failure to do so can result in back or other injury.
- To allow for proper air ventilation, leave a minimum 5cm of space between the top, rear and sides of the Beverage Centre to allow sufficient cooling of the condenser.
- Be sure to leave enough space for the door opening to avoid damage to the appliance or personal injury.

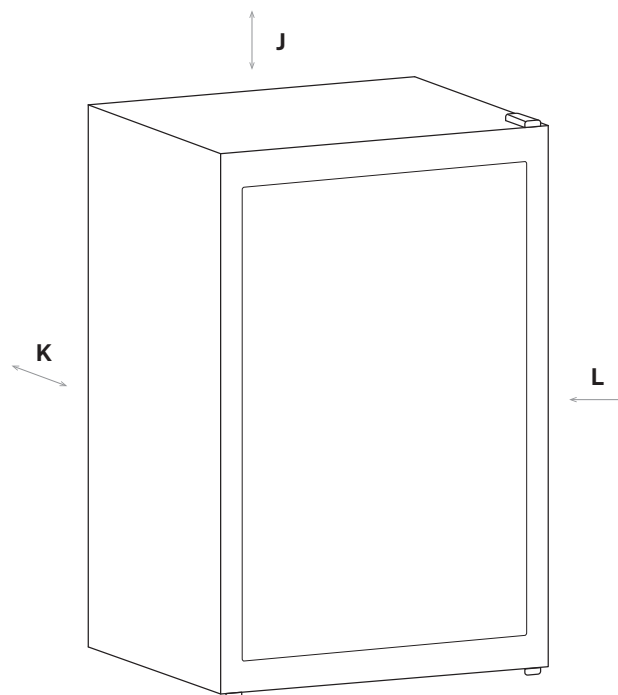

Minimum clearances (mm)

J	50	L	50
K	50		

Installing Your Beverage Centre

Electrical Connection

- Ensure the product is installed in a way that allows easy access to plug or unplug the power cord.
- Insert the product's plug into a dedicated socket to prevent accidental power disconnection. Avoid plugging other appliances into this socket, and do not use extension cords or multiport adapters, as their combined weight may cause them to fall from the wall.
- Refer to the product's rating label to ensure it meets the necessary power supply requirements.
- The product must be properly grounded for safety.
- Operating voltage for your Beverage Centre is 220-240V at 50Hz.
- The manufacturer does not take the responsibility of the damages that occur due to ungrounded usage.
- Any electrical work that is required to install this appliance must be carried out by a qualified electrician.
- **WARNING:** THIS APPLIANCE MUST BE EARTHED
- Before making any electrical connections, ensure that:
 - Electrical safety is only guaranteed when the earth system of your house in accordance with the related local regulations.
 - Do not bend, stretch or pull the supply cable to avoid electric shock.
 - Ensure the power socket is suitable for the Maximum power of the machine (fuses in the power circuit must be 10 amp).
 - The supply voltage should be the same as that indicated in the technical specifications and the appliance rating plate.
 - The appliance should be earthed and in compliance with the applicable law.
- When installed, the power socket must be within easy reach.
- If the socket outlets in your home are not suitable for the plug supplied with this unit check with a qualified electrician for a replacement.
- To avoid the risk of overloading your plug socket, the use of adapters, multiple connectors or extension cables are not recommended. The appliance must be connected to a 220-240 volt 50Hz AC supply by mean of a three pin socket, suitably earthed and protected by a 10 amp fuse.
- The plug contains a removable fuse cover that must be refitted when the fuse is replaced. If the fuse cover is lost or damaged, the plug must not be used until a replacement cover has been fitted or the plug is replaced.
- A damaged plug should be cut off as close to the plug body as possible, the fuse should be removed and the plug disposed of safely.
- When positioning the appliance, ensure the supply cord is not trapped or damaged.
- Do not locate multiple portable socket-outlets or portable power supplies at the rear of the appliance.
- If power supply cord is damaged, it must replaced by the manufacturer or its service agent or a similar qualified person in order to avoid a hazard.
- The appliance is designed for indoor use only and must be protected from rain, moisture and extreme temperature variations.
- This appliance is designed for household use only. Do not use the appliance for industrial and commercial use, or any other purpose.

Installing Your Beverage Centre

Reversing the Door Swing

CAUTION: Whilst performing the below steps, you will need to tilt the Beverage Centre backward to access the lower Hinge. Do not tilt more than 45 degrees.

CAUTION: Do not lay the unit flat on its side to avoid damage.

Remove the Top Hinge Cover

- Detach the plastic hinge cover at the top of the door and set it aside.



Unscrew the Top Hinge Bracket

- Use a screwdriver to remove the 3 screws holding the top metal hinge bracket. Carefully remove the door and place it on a cushioned surface to avoid scratches or damage.

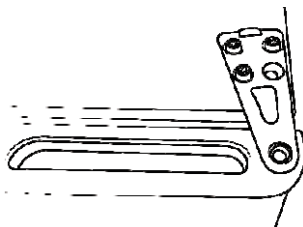

Adjust the Bottom Hinge and Feet

- Tilt the Beverage Centre backward no more than 45 degrees.
- Unscrew the bottom hinge and front feet.
- Reposition the front feet to the original location of the bottom hinge. Then, attach the bottom hinge to the original position of the front feet.

Reinstall the Top Hinge on the Opposite Side

- Remove the plastic insert from the opposite side of the top hinge area.
- Attach the top hinge bracket to the opposite side using the screws you set aside earlier.

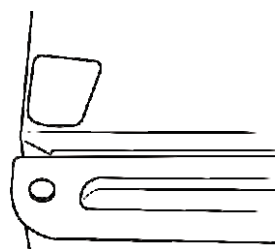

- Insert the plastic insert into the vacant slot on the other side of the top hinge area.

Reattach the Door

- Carefully reverse the glass door to the other side. Ensure it is securely aligned with the hinges.

Replace the Hinge Cover

- Place the plastic hinge cover back onto the top hinge to complete the process.

Your Beverage Centre is now ready for use with the door opening direction reversed.

Operating Instructions

Before First Use

- Ensure that the Beverage Centre is correctly installed following the Installing Your Beverage Centre section.
- Remove all packaging, including foam backing and tape securing shelves.
- Before use, wipe all parts of the unit with a warm, soapy cloth, and rinse and dry thoroughly. Place all parts back in the appliance after cleaning.
- To avoid damaging the compressor, before switching on the appliance for the first time, ensure it is positioned in its desired final location and it is in an upright position for at least 8 hours before plugging in and switching on the power.
- When you first switch on the Beverage Centre, the compressor will run continuously until the Beverage Centre reaches the set temperature. During this period of time, try not to open the door frequently or place bottles inside the appliance. After about 3–4 hours, you can start loading the unit.
- You may experience an odour from the appliance when it is powered on for the first time. This is normal and will fade when your appliance starts to cool.

Switching the Power On/Off

To turn the Beverage Centre on or off, press and hold the power button for 6 seconds.

CAUTION: If the appliance has been switched off, wait at least 5 minutes before turning it back on to avoid unnecessary damage to the compressor.

Adjusting the Temperature

Use the Plus / Increase (+) or the Minus / Decrease (-) adjustment buttons to set the desired temperature in 1°C increments. The desired temperature will flash while being changed and will become set after 6 seconds of no change.

The temperature range is 0° – 22°C.
The preset temperature is 4°C (39°F).

To switch between Celsius and Fahrenheit temperature display, press the Plus / Increase (+) and the Minus / Decrease (-) buttons simultaneously for 2 seconds. The display will update with the set temperature symbol (°C/°F).

The display shows the current internal temperature when the Beverage Centre, is on.

NOTE: The appliance will run continuously until it reaches the set temperature. Continuous noise from the compressor and refrigeration system is normal and not a defect.

Control Panel

A. Power Button

B. Light Button

C. Digital Display

D. Plus / Increase Button

E. Minus / Decrease Button

F. Temperature Display Button Combination

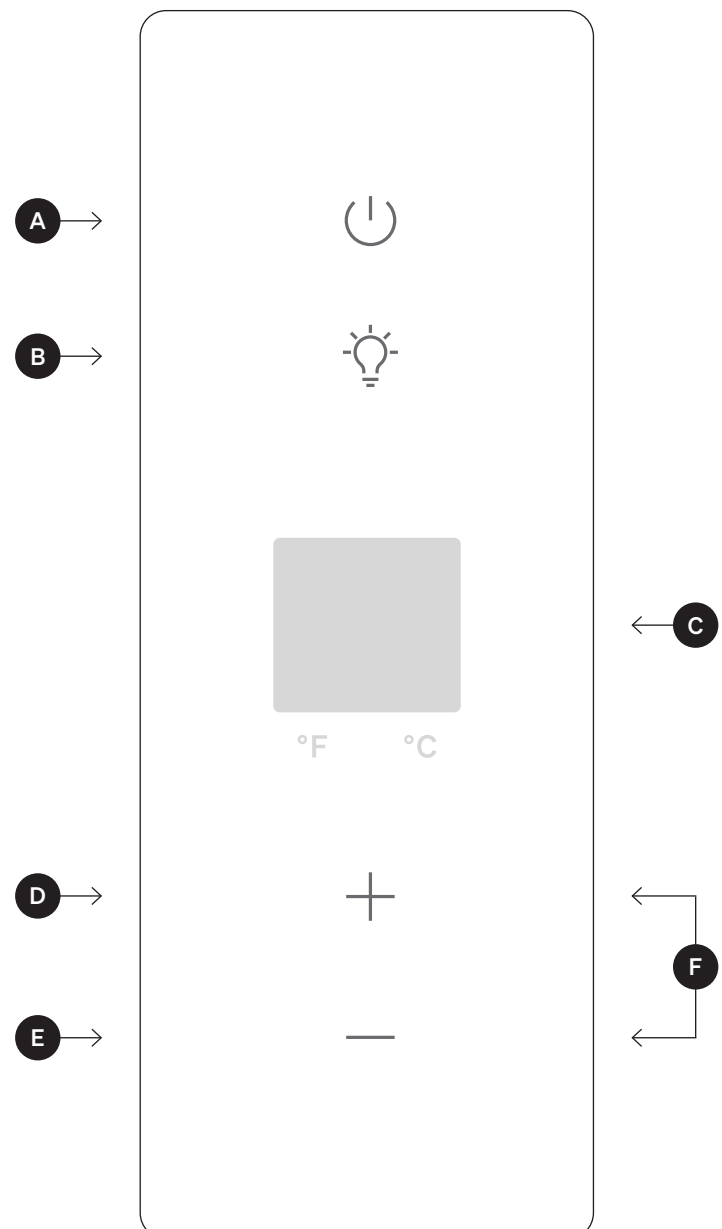

Operating Instructions

LED Display

The display shows the current internal temperature when the Beverage Centre, is on.

NOTE: This may fluctuate as the refrigerator cycles on/off. This is not a fault.

NOTE: The appliance will run continuously until it reaches the set temperature. Continuous noise from the compressor and refrigeration system is normal and not a defect.

Using the Internal Light

To turn the light on or off, press the Light button.

NOTE: We recommend to only turn on the light only when required.

Automatic Defrosting

The appliance automatically defrosts every 4 hours, with each defrost cycle lasting 20 minutes.

During the defrost cycle the compressor will stop.

Operating Conditions

For optimal performance, install the appliance in an area where the ambient temperature is between 16°C and 32°C.

Placing the unit in environments outside this range (extremely hot or cold) may cause temperature fluctuations and prevent the unit from reaching its specified operating temperature range.

Noise

Initially, the Beverage Centre may operate at a higher speed to cool quickly, resulting in louder sounds. Once the internal temperature reaches a certain level, the noise will decrease. Various sounds, such as those from the compressor starting or ending its operation, parts expanding or contracting, or control devices operating, are normal.

Beverage Storage Advice

Prepare the Shelves: Ensure all shelves are correctly installed before placing items inside.

Set the Temperature: Adjust the Beverage Centre to the desired temperature and allow several hours for cans to reach this temperature.

Beverage Arrangement: To maintain good air circulation in the Beverage Centre, do not let any bottles or cans touch the back wall of the cabinet.

The capacity for storage in the Beverage Chiller may be different due to bottles and cans of different shapes and sizes. Storing large bottles will reduce the maximum capacity.

NOTE: Shelves may need to be removed for larger bottles.

Do Not Overload: Avoid exceeding the appliance's maximum capacity, as this could affect performance.

Condensation on Glass

CAUTION: During summer or in humid conditions, condensation may form on the glass door. This is normal and can be wiped off with a damp cloth.

Removing the Shelves

1. Remove all bottles or cans from the shelf before attempting to remove it.
2. Lift the inner end of the shelf upward.
3. Pull the shelf out of the Beverage Centre completely.

Cleaning & Maintenance

Defrosting

Automatic Defrosting: With a built-in program, the unit controls the frequency and duration of freezer defrosting, eliminating the need to manually defrost the freezer. For more information, please see page 14.

Prior to Cleaning Your Beverage Centre

- Before cleaning, always turn off the power switch and disconnect the power plug.
- Ensure no water enters the switch, control panel, door lamp, or top control box during cleaning.

LED Light Replacement

Only a professional should replace the LED light source in this product.

Cleaning Instructions

General Precautions

- Always turn off the power and unplug the appliance before performing any cleaning.
- Remove all shelves and parts before cleaning.
- Never flush the Beverage Centre with water or pour water directly over it, as this may compromise electrical insulation.

Cleaning the Exterior

1. Use a mild cleaner to remove dirt from the exterior.
2. Wipe with a clean, soft cloth and allow the surface to dry naturally.
3. Dust behind the Beverage Centre and on the ground regularly to improve cooling efficiency and energy savings.

Cleaning the Door Seal

- Use clean water and a soft cloth to wipe the door sealing strip.
- Allow it to dry naturally.

Cleaning the Interior

1. Use a soft cloth with warm water or a neutral cleaner to wipe the interior surfaces (excluding the door seal).
2. Clean shelves and frames with a mild detergent, then dry them with a soft cloth.
3. Avoid using soap, detergent, scrub powders, or spray cleaners inside, as these can cause odors.
4. Clean the interior regularly to prevent odours from developing.

Cleaning the Shelves and Parts

- Wash removable parts individually with soapy water by hand.
WARNING: Do not place them in a dishwasher.
- Dry thoroughly before reinserting into the Beverage Centre.

Cleaning Materials to Avoid

- Do not use hard brushes, steel wool, wire brushes, abrasives, or solvents such as alcohol, acetone, acids, or alkaline cleaners.
- Avoid boiling water or flammable, explosive, or corrosive materials. These may damage or deform the appliance.

After Cleaning

Reconnect the power plug and turn the Beverage Centre back on.

On Vacation

Short Vacations (up to 3 weeks)

- Keep the Beverage Centre running continuously. Ensure the door is securely closed to maintain proper conditions for your beverages.

Long Vacations (3 weeks or more)

- Remove all beverages, unplug the appliance, and leave the doors open to allow air circulation, preventing odour and mould.

NOTE: If the Beverage Centre will be empty for an extended period, switch it off, defrost, clean, dry thoroughly, and leave the door open to prevent mould from developing.

Power failure

Short-term power failures usually do not significantly affect the Beverage Centre's temperature. However during prolonged power outages it is advised to empty the Beverage Centre compartment.

Troubleshooting

For Minor Faults

Problem	Solution
The Door Does Not Close Properly	<ul style="list-style-type: none"> • Remove obstructions preventing closure. • Ensure door compartments and shelves are correctly placed. • Inspect door seal for warping or tears. • Check that the appliance is level.
Unusual Noises	<ul style="list-style-type: none"> • Ensure the appliance is on a flat, stable surface. • Verify adequate spacing to prevent contact with other items. • Bubbling and gurgling sounds are normal coolant noises. • Popping and cracking sounds are due to interior wall expansion and contraction.
The Beverage Centre Door Will Not Open	<ul style="list-style-type: none"> • Wait a few minutes after opening to allow air pressure to equalise before trying again.
The Compressor Runs Constantly	<ul style="list-style-type: none"> • Adjust temperature to a warmer setting. • Check for open or obstructed doors. • Ensure the room temperature is not unusually high.
The External Beverage Centre Surface Is Warm	<ul style="list-style-type: none"> • Warm exterior walls are normal due to the compressor transferring heat from inside.
Smells/Odours	<ul style="list-style-type: none"> • Check for spoiled drinks and remove if necessary. • Clean up spillages promptly following the manufacturer's instructions.

For Serious Faults

Some minor faults can be fixed by referring to the table above, however if an emergency or serious fault occurs, immediately set all controls to their off positions and disconnect the power from the source.

If a serious fault occurs, DO NOT attempt to repair the Beverage Centre yourself, instead wait for a service agent to do so.

For assistance or to organise an authorised service agent contact our After Sales Support by calling 1300 11 4357, or by emailing support@residentiagroup.com.au.

Please note that if a service agent is asked to attend whilst the product is under warranty and finds that the problem is not the result of an appliance fault, then you may be liable for the cost of the call out charge.

The appliance must be accessible for the service agent to perform any necessary repair. If your appliance is installed in such a way that a service agent is concerned that damage will be caused to the appliance or your kitchen, then they will not complete a repair.

Please refer to the Warranty Information to learn more.

Technical Specifications

Product Specifications

Model	OCBFS102SB
Capacity (Cans)	102
Capacity (Litres)	98L
Installation	Freestanding
Dimensions (W × D × H mm)	470 × 475 × 840
Rated Voltage / Frequency	AC 220–240V/50Hz
Protection Class	I
Climate Class	T
Rated Current	0.5A
Rated Lamp Power	1W
Refrigerant	R600a/17g
Max Noise Level	39 dB(A)

Purchase Details

Attach your receipt to this page

For future reference, please record the following information which can be found on the rating plate and the date of purchase which can be found on your sales invoice.

Store Details

Store Name

Address

Telephone

| Purchase Date

Product Details

Model No.

Serial No.

Warranty Information

WARRANTY TERMS AND CONDITIONS BEVERAGE CENTRES

This document sets out the terms and conditions of the product warranties for Residentia Group Appliances. It is an important document. Please keep it with your proof of purchase documents in a safe place for future reference should you require service for your Appliance.

1. In this warranty
 - (a) 'acceptable quality' as referred to in clause 10 of this warranty has the same meaning referred to in the ACL;
 - (b) 'ACL' means Trade Practices Amendment (Australian Consumer Law) Act (No.2) 2010;
 - (c) 'Appliance' means any Residentia Group product purchased by you accompanied by this document;
 - (d) 'ASR' means Residentia Group authorised service representative;
 - (e) 'Residentia Group' means Residentia Group Pty Ltd of 165 Barkly Ave, Burnley VIC 3121, ACN 70 600 546 656 in respect of Appliances purchased in Australia;
 - (f) 'major failure' as referred to in clause 10 of this warranty has the same meaning referred to in the ACL and includes a situation when an Appliance cannot be repaired or it is uneconomic for Residentia Group, at its discretion, to repair an Appliance during the Warranty Period;
 - (g) 'Warranty Period' means:
 - (i) where the Appliance is used for personal, domestic or household use (i.e. normal single family use) as set out in the instruction manual, the Appliance is warranted against manufacturing defects for 36 months, following the date of original purchase of the Appliance;
 - (h) 'you' means the purchaser of the Appliance not having purchased the Appliance for re-sale, and 'your' has a corresponding meaning.
2. This warranty only applies to Appliances purchased and used in Australia and is in addition to (and does not exclude, restrict, or modify in any way) any non-excludable statutory warranties in Australia.
3. During the Warranty Period Residentia Group or its ASR will, at no extra charge if your Appliance is readily accessible for service, without special equipment and subject to these terms and conditions, repair or replace any parts which it considers to be defective. Residentia Group or its ASR may use remanufactured parts to repair your Appliance. You agree that any replaced Appliances or parts become the property of Residentia Group. This warranty does not apply to light globes, batteries, seals, filters or similar perishable parts.
4. Parts and Appliances not supplied by Residentia Group are not covered by this warranty.

Warranty Information

5. You will bear the cost of transportation, travel and delivery of the Appliance to and from Residentia Group or its ASR. If you reside outside of the service area, you will bear the cost of:
 - (a) travel of an authorised representative;
 - (b) transportation and delivery of the Appliance to and from Residentia Group or its ASR, in all instances, unless the Appliance is transported by Residentia Group or its ASR, the Appliance is transported at the owner's cost and risk while in transit to and from Residentia Group or its ASR.
6. Proof of purchase is required before you can make a claim under this warranty.
7. You may not make a claim under this warranty unless the defect claimed is due to faulty or defective parts or workmanship. Residentia Group is not liable in the following situations (which are not exhaustive):
 - (a) the Appliance is damaged by:
 - (i) accident
 - (ii) misuse or abuse, including failure to properly maintain or service
 - (iii) normal wear and tear
 - (iv) power surges, electrical storm damage or incorrect power supply
 - (v) incomplete or improper installation
 - (vi) incorrect, improper or inappropriate operation
 - (vii) insect or vermin infestation
 - (viii) failure to comply with any additional instructions supplied with the Appliance;
 - (b) the Appliance is modified without authority from Residentia Group in writing;
 - (c) the Appliance's serial number or warranty seal has been removed or defaced;
 - (d) the Appliance was serviced or repaired by anyone other than Residentia Group, an authorised repairer or ASR.
8. This warranty, the contract to which it relates and the relationship between you and Residentia Group are governed by the law applicable where the Appliance was purchased.
9. To the extent permitted by law, Residentia Group excludes all warranties and liabilities (other than as contained in this document) including liability for any loss or damage whether direct or indirect arising from your purchase, use or non use of the Appliance.
10. For Appliances and services provided by Residentia Group in Australia, the Appliances come with a guarantee by Residentia Group that cannot be excluded under the Australian Consumer Law. You are entitled to a replacement or refund for a major failure and for compensation for any other reasonably foreseeable loss or damage. You are also entitled to have the Appliance repaired or replaced if the Appliance fails to be of acceptable quality and the failure does not amount to a major failure. The benefits to you given by this warranty are in addition to your other rights and remedies under a law in relation to the Appliances or services to which the warranty relates.
11. At all times during the Warranty Period, Residentia Group shall, at its discretion, determine whether repair, replacement or refund will apply if an Appliance has a valid warranty claim applicable to it.
12. Missing parts are not covered by warranty. Residentia Group reserves the right to assess each request for missing parts in a case by case basis. Any parts that are not reported missing in the first week after purchase will not provide free of charge.
13. To enquire about claiming under this warranty, please follow these steps:
 - (a) carefully check the operating instructions, user manual and the terms of this warranty;
 - (b) have the model and serial number of the Appliance available;
 - (c) have the proof of purchase (e.g. an invoice) available;
 - (d) telephone the numbers shown below.
14. You accept that if you make a warranty claim, Residentia Group and its ASR may exchange information in relation to you, in order to enable Residentia Group to meet its obligations under this warranty.

IMPORTANT

Before calling for service, please ensure that the steps in point 13 have been followed.

Contact Service: Please call 1300 11 HELP (4357)

The Australian Consumer Law requires the inclusion of the following statement with this warranty:

Our goods come with guarantees that cannot be excluded under the Australian Consumer Law. You are entitled to a replacement or refund for a major failure and for compensation for any other reasonably foreseeable loss or damage. You are also entitled to have the goods repaired or replaced if the goods fail to be of acceptable quality and the failure does not amount to a major failure.

EST. 1981

Designed to Enhance

omega

Omega is proudly owned, designed and engineered
in Australia by Residentia Group Pty. Ltd.

@residentia.group
www.residentia.group



E2447